



Subaru WRX VB High Flow DI Injector Installation Guide

PRODUCT PART SKU#: IAG-AFD-2505

Warning! Please follow all warnings and instructions found in your vehicle service manual. The following instructions must be read and fully understood before beginning installation. Failure to follow these instructions may result in vehicle damage, personal injury, or death. If these instructions are not fully understood, do not attempt installation.

Please note that this product does require vehicle calibration. Please ensure provisions are made prior to installation, Tuning Guides are available for your preferred tuner if needed. If you are already in touch with a tuner, please have them reach out to support@iagperformance.com or access the Tuning Guide on the product page. If you do not currently have a tuner, we will gladly connect you with someone within the dealer network.

Required tools:

-
- ECU programming interface or other calibration delivery method
- Safety glasses
- Fire extinguisher (Class B minimum recommended)

Consumables:

- Lint free absorbent towels
- Disposable rubber gloves

Additional recommended OEM parts (not included):

Description	Quantity	Part #

CLEANLINESS IS PARAMOUNT!

Every serialized injector is production tested for gross leak, fine leak, and leak decay for quality control. These injectors left the factory with no leaks! Contamination is the #1 cause of injector leaks. Injector contamination can come from poor fuel quality, dirt or debris introduced during installation, or dirt and debris from handling before installation. It is imperative that the engine, workspace, tools, and handling is as clean as possible during the installation process. Use fuels and ethanol from trusted sources!

1. Disconnect the negative battery terminal.

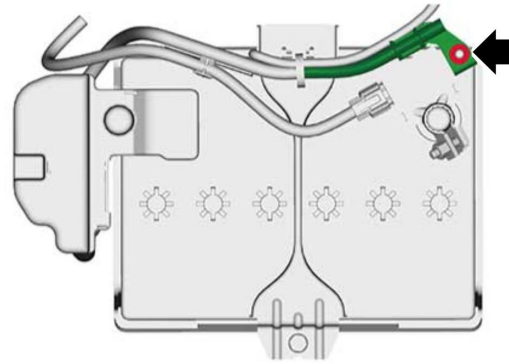

Figure 1

2. Remove the bolts which secure the intercooler and remove the RH intercooler mounting bracket from the intake manifold assembly.

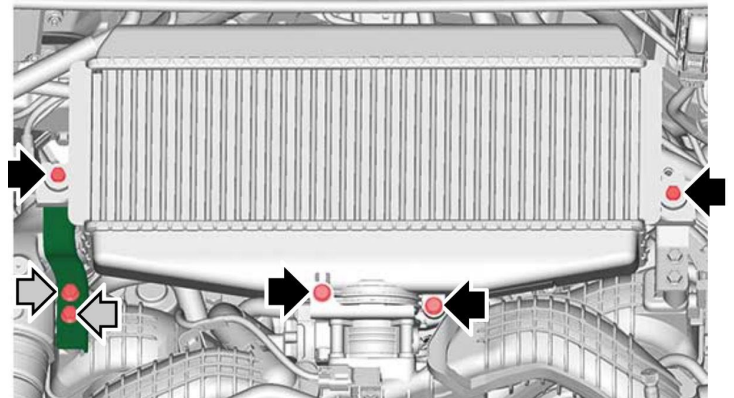
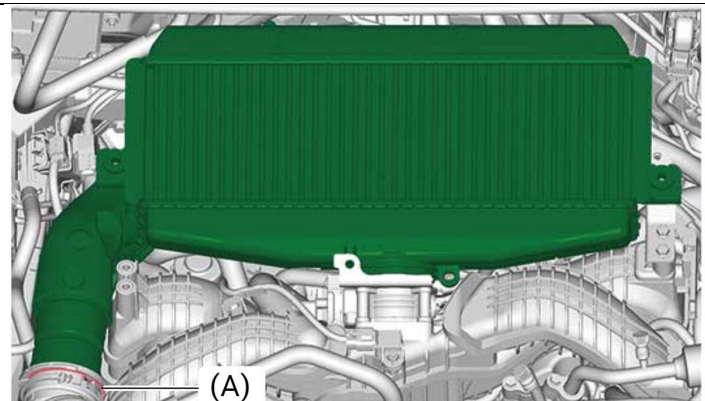
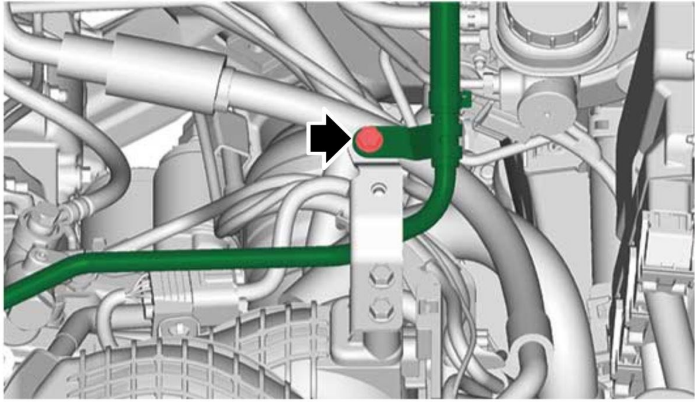
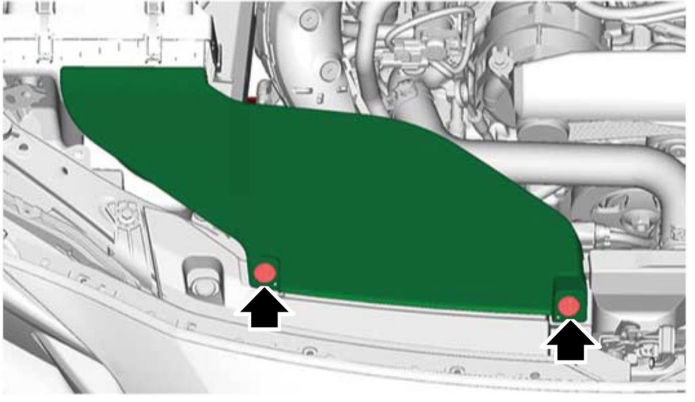
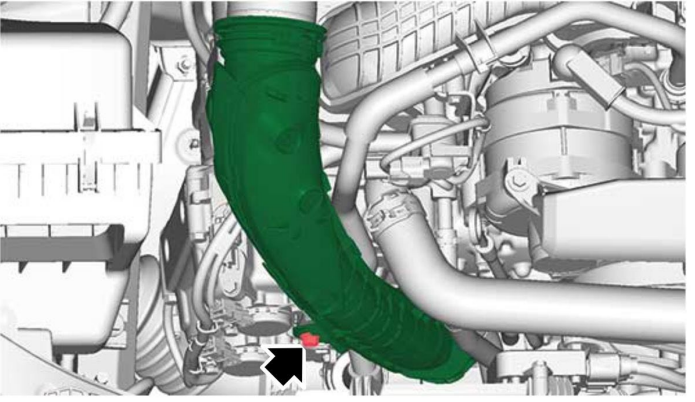

Figure 2

3. Release the locking spring on the intake duct (A) and remove the intercooler and the intake duct as a single unit.



<p>4. Remove the bolt securing the vacuum pipe assembly bracket to the LH intercooler mounting bracket. (Manual Transmission model)</p>	<p>Figure 3</p> 
<p>5. Remove the clips and remove the air intake duct.</p>	<p>Figure 4</p> 
<p>6. Remove the bolt to loosen the intake duct then position it aside.</p>	<p>Figure 5</p> 
	<p>Figure 6</p>

7. Disconnect the throttle body connector (A) and remove the bolts securing the throttle body then, move the throttle body aside so that it does not interfere with the work.

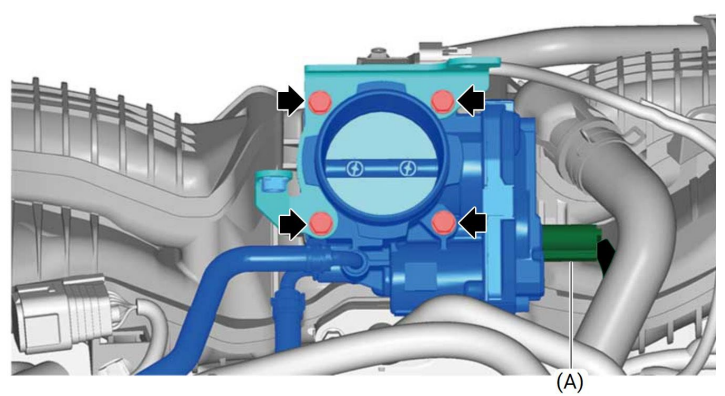

Figure 7

8. Disconnect the connector (A) and remove the clip (B). Disconnect the connector (C) and remove the clip (D). Remove the PCV pipe from the intake manifold assembly.

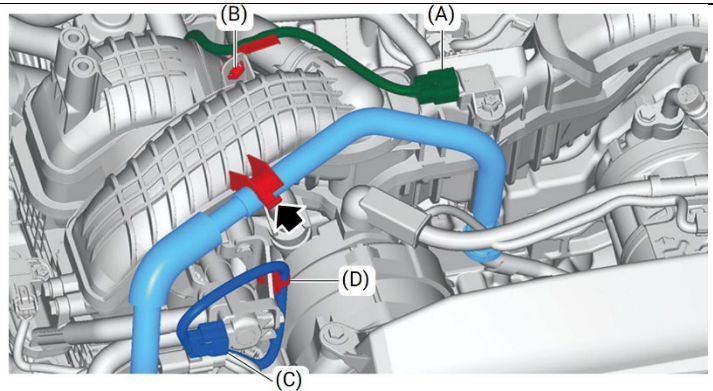

Figure 8

9. Remove the connector (A) and connector (B). Disconnect the fuel delivery tube (C). Remove the fuel delivery tube clamp (D). Disconnect the evaporation hose (E).

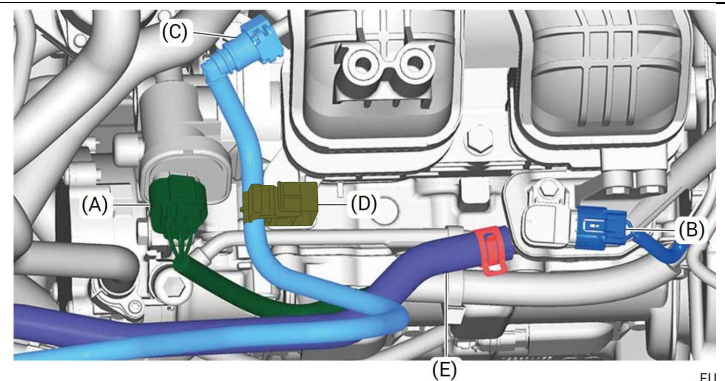

Figure 9

10. Remove the clip (A) securing battery cable assembly and release the claw (B).

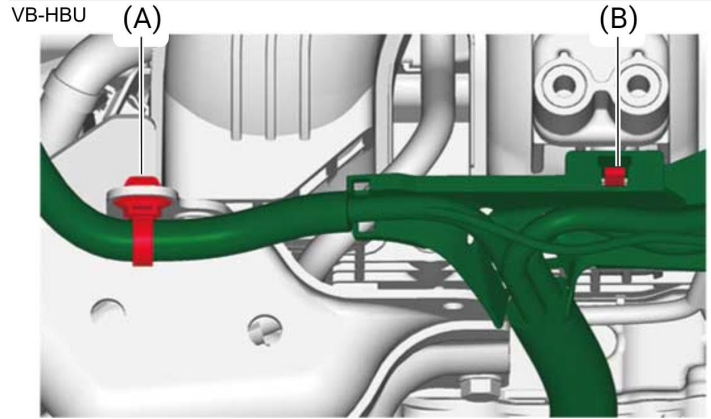

Figure 10

11. Remove the primary fuel pipe protector.

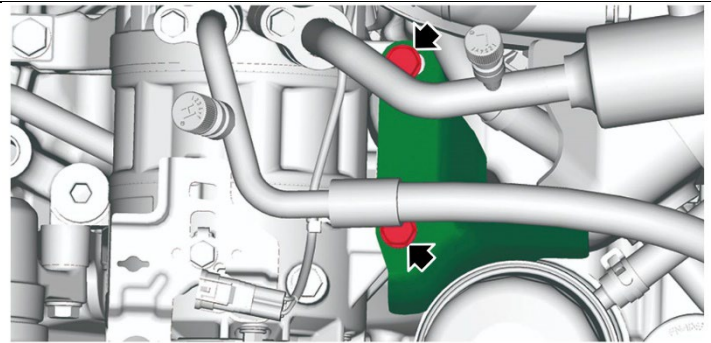

Figure 11

12. Remove the secondary fuel pipe protector.

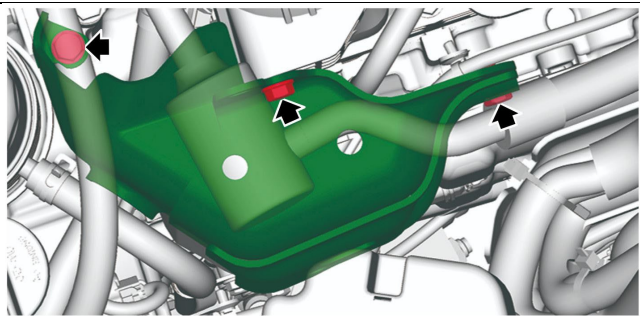

Figure 12

13. Disconnect the connector (A)
 Disconnect the fuel delivery pipe (B)
 Remove clip C and clip D

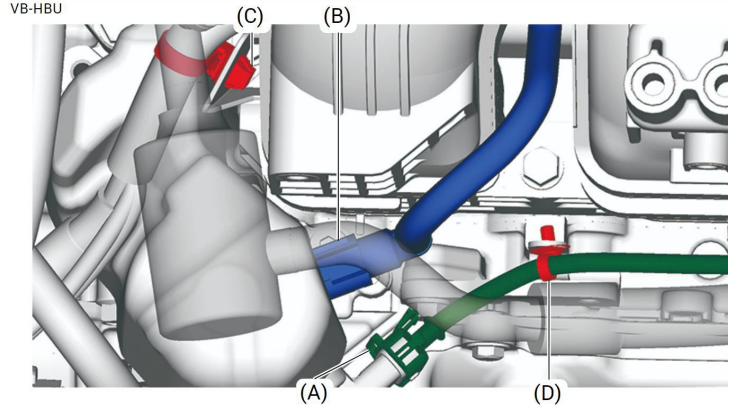

Figure 13

14. Disconnect the connector (A).
 Remove clip B and clip C.

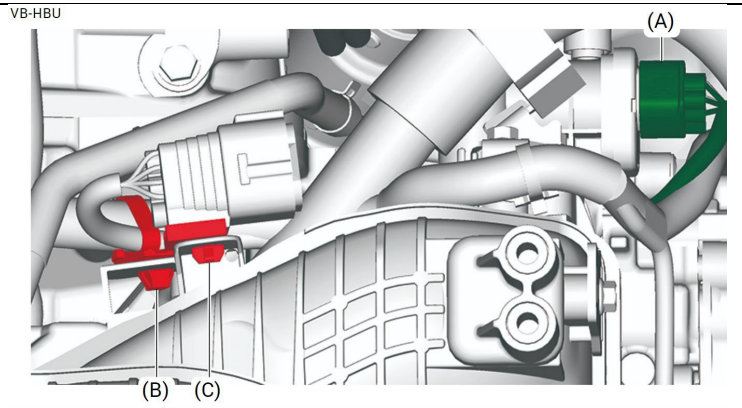

Figure 14

15. Remove the clip (A) from the wire harness bracket.
 Remove the wire harness bracket and remove the clip (B).

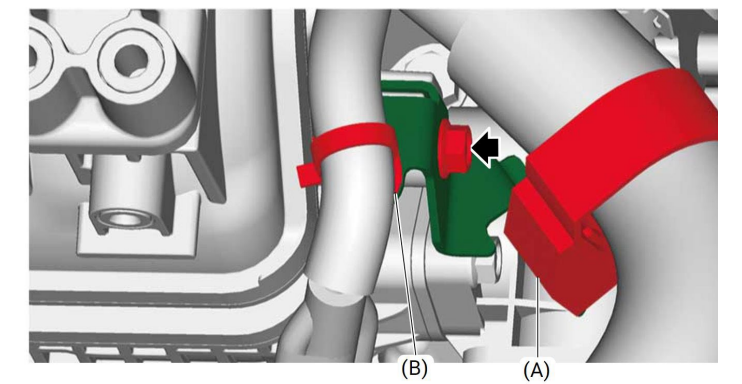

Figure 15

16. Remove the PCV hose from the intake manifold assembly and the PCV valve.

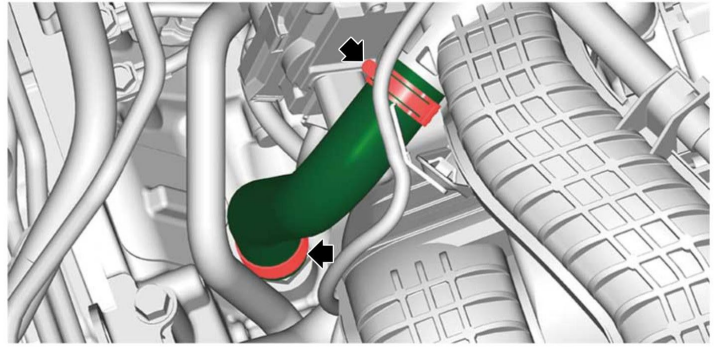

Figure 16

17. Remove the 2 nuts securing the EGR pipe.

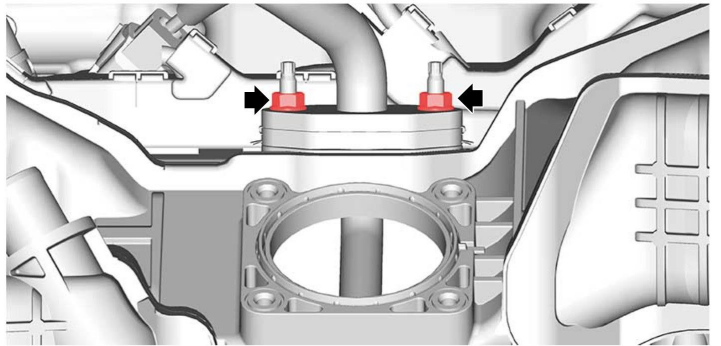

Figure 17

18. Remove the EGR tube studs.

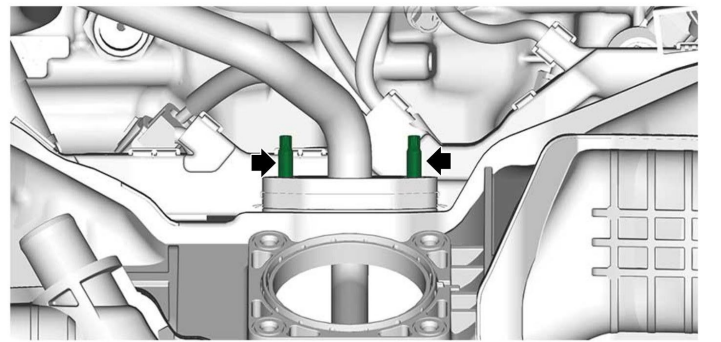

Figure 18

19. Remove the 6 bolts securing the intake manifold, then remove the intake manifold.

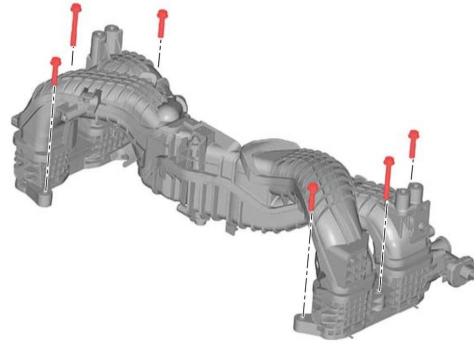

Figure 19

20. Remove the high-pressure pump insulator.

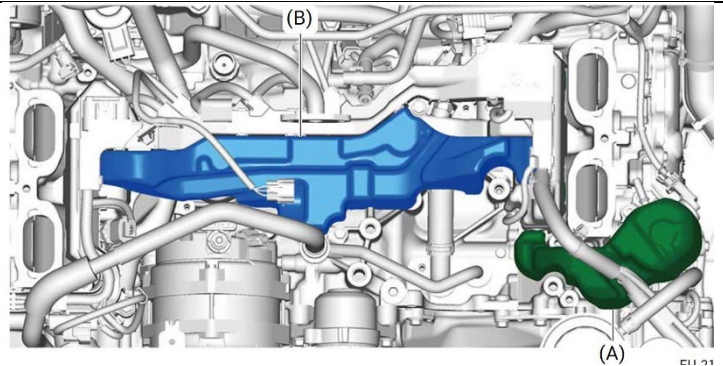

Figure 20

21. Remove the high-pressure fuel line from the high-pressure pump and fuel rail.

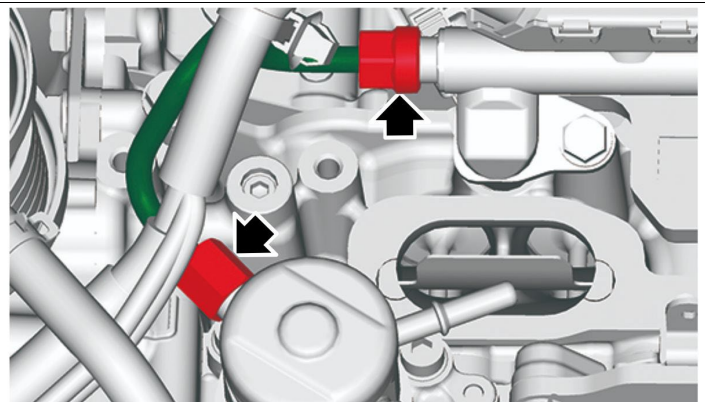

Figure 21

22. Remove the flare nut (A) and bolt (B), and then remove the high-pressure fuel delivery pipe assembly.

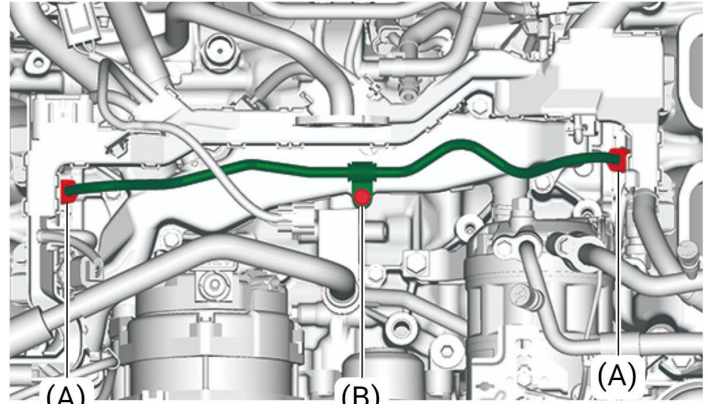

Figure 22

23. Disconnect the connector (A) from the fuel pressure sensor. Disconnect the connectors (B) from the 4 fuel injectors and remove the fuel injector pipes.

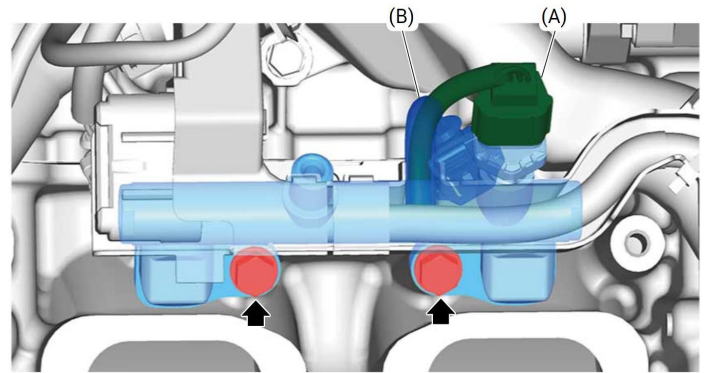

Figure 23

24. Remove the holder from the fuel injector assembly.

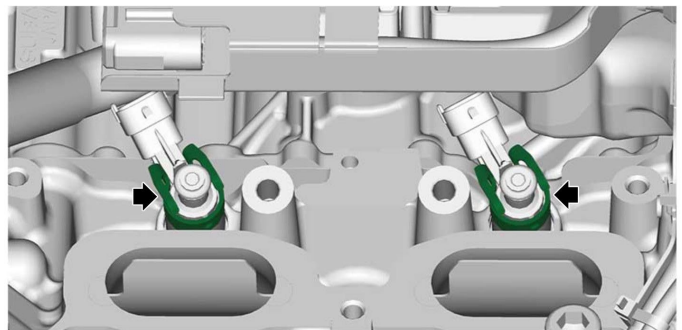

Figure 24

25. Using an injector removal tool, remove the fuel injectors from the cylinder head. Do as shown in the following Steps 26 to Step 28 for all 4 injectors.

A special tool (ST) is required for the next steps.

Injector Removal tool P/N: 18356AA010

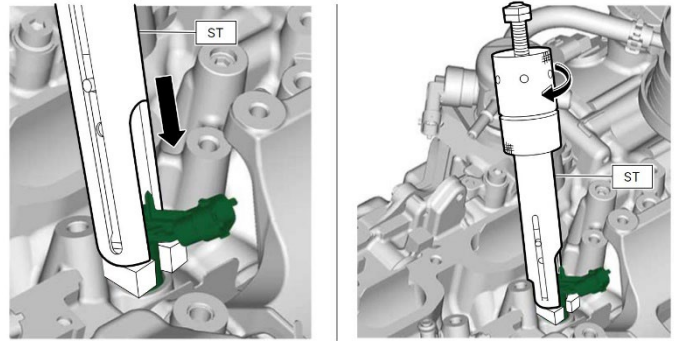

Figure 25

26. Set the removal tool adapter to the fuel injector #1.

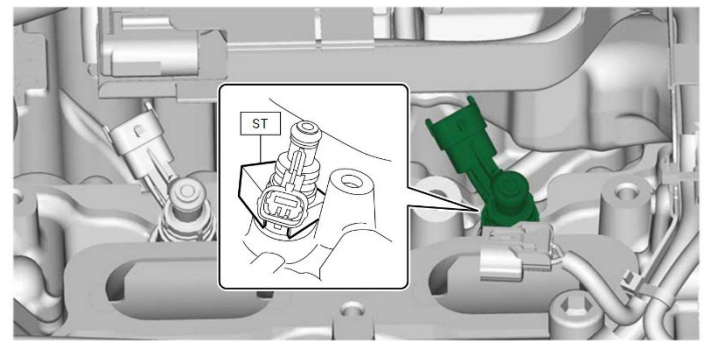

Figure 26

27. Pinch the fuel injector groove (B) with the claw (A) of the injector removal tool (ST).

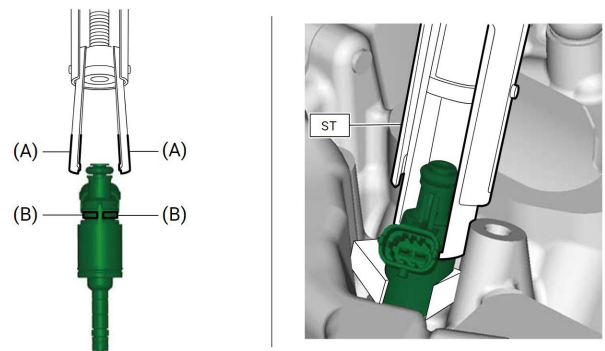

Figure 27

28. Press the tool to the cylinder head, then screw in the threaded section of the injector removal tool clockwise and remove the fuel injector from the cylinder head.

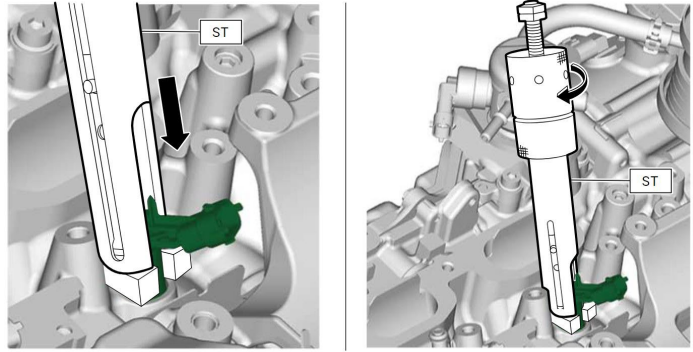

Figure 28

29. Remove the fuel injector spacers from your old injectors and place them on your new ones.



Figure 29

30. Using clean engine oil lubricate the o-ring on top of the injectors.



Figure 30

31. Place the injectors into the fuel rails and align the protrusion part of the injectors (the error proof pin) with the hole on the rail.

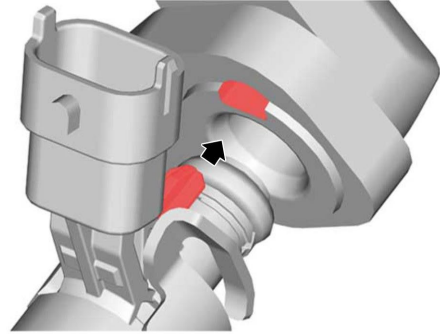

Figure 31

32. Using clean engine oil lubricate the combustion seals on the tip of the injectors.



Figure 32

33. **NOTE: Do this step only when you are ready to place the injectors into the vehicle. The injectors must be installed onto the rail before doing this step. For demonstration purposes Figure 33 will not be installed on a fuel rail.**

Use a combustion seal sizing tool to compress the seals on the tip of the injector.

Bosch P/N: **0986-616-099-955** combustion seal sizing tool or equivalent



Figure 33

34. Push the sizing tool onto the injector until it reaches the body of the injector as shown in Figure 34. Allow the seals to compress for approximately 15 seconds.



Figure 34

35. After compressing the seals immediately insert the fuel rail and injectors back into the cylinder head. Firmly press down on areas marked A and B to seat the injectors.

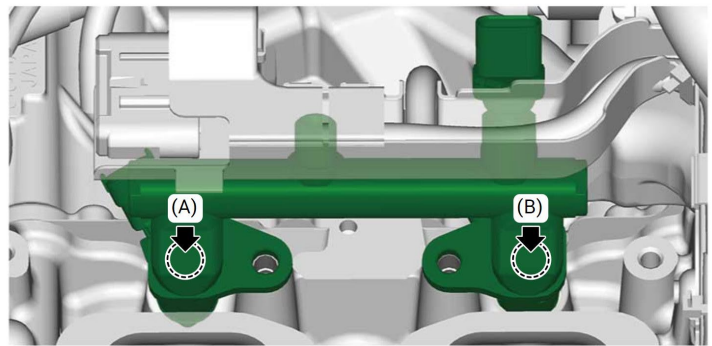

Figure 35

36. Install and torque the OEM fuel rail bolts to **19 Nm (14 ft-lb)**.
Connect the fuel pressure sensor (A).
Connect all 4 fuel injector connectors (B).

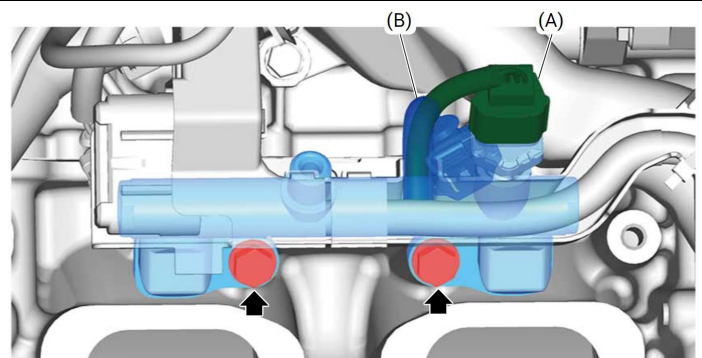

Figure 36

37. Install the OEM high-pressure crossover line to the fuel rails, and temporarily tighten by hand. Install and tighten bolt (B) to secure the line in place. Then torque the compression nuts (A) to **28 Nm (20.7 lb-ft)**.

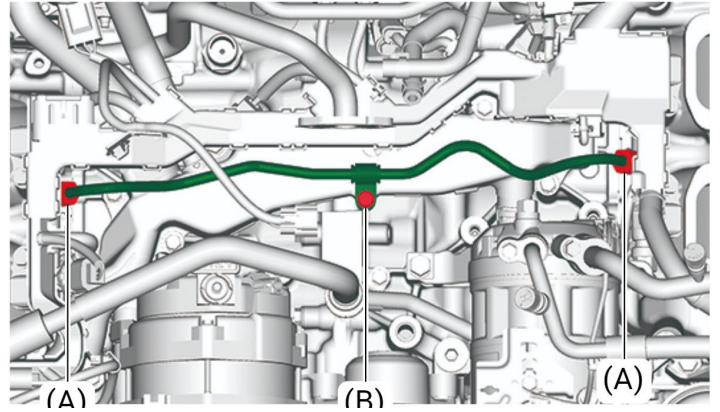

Figure 37

38. Install the OEM high-pressure line, then tighten the compression nuts to **28 Nm (20.7 ft-lb)**.

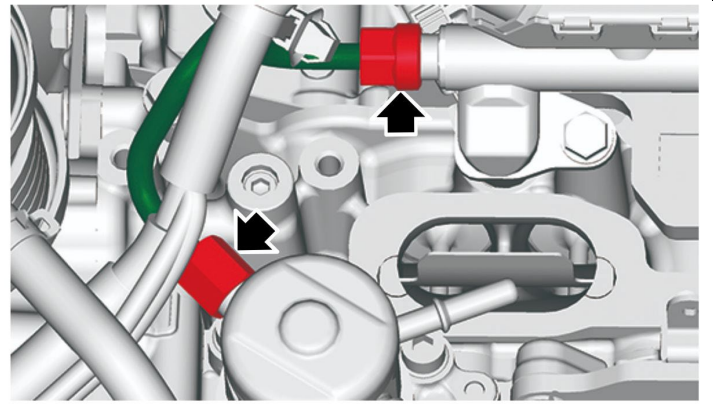

Figure 38

Once the Nostrum Injectors are installed, reinstallation of all remaining components can begin. Follow the steps of disassembly listed above in reverse to re-install components starting with step 20. Follow all torque specs that are included in each step where applicable (when applicable the torque specifications for re-assembly are in parentheses in Nm at the end of the particular disassembly step). If a torque spec is not included in a step where it seems applicable assume snug fit with a wrench or socket wrench.

Hardware installation is complete.

Calibration

Do not start your vehicle, this product requires calibration. Please contact your tuner or refer to the Nostrum Tuning Guide to make the necessary changes prior to starting the vehicle. Once calibration is complete, please proceed to the next step.

First Start-Up

1. Be sure to remove all installation tools and loose items from the engine compartment. Follow good, safe practices when working on your vehicle. Be sure to reassemble all parts and components according to your OE service manual.
2. Key cycle the vehicle into the "Accessory On" position (do not go to the Start position). The low-pressure fuel pump will activate and the fuel system will pressurize. Check the high-pressure fuel pump and the low-pressure system for leaks. If no leaks are found, proceed to Step 3.
3. Cycle the key to the Start position and let the vehicle attempt several start cycles. Remember that the fuel lines, pump, and part of the fuel rail are filled with air, therefore this step is necessary to evacuate that air and get the system charged. If it starts, continue with the following steps. If it does not, key off the vehicle. Check the high-pressure lines to the fuel rail, to the pump and the pump itself for leaks. If no leaks are found, proceed to step 4.
4. Key cycle one more time to Start. Engine should start-up and idle. If so, continue with the following steps. If not, repeat Steps 2-4 again.
5. Let the car idle for a few minutes. Check for leaks in the low and high-pressure systems again.
6. Installation is complete!

NOTE: a fault code may appear at the first key cycle due to the extended cranking time or the low-pressure in the fuel rail, both due to the air in the fuel system.

This code should self-clear after the OEM defined quantity of key cycles.

NOTE: Please check for fuel leaks after driving the vehicle and letting it cool for an extended period of time. Fittings may loosen after the first heat cycle due to thermal expansion and contraction. Retighten fittings if needed.

For additional technical & software support please contact:

Email: support@iagperformance.com

Web page: <https://www.iagperformance.com/service-support/>

Phone: 410-840-3555 (during normal business hours)

IAG Performance

Revision	Notes	Date
1.0	Initial Draft with IAG formatting	10/17/24
1.1	Instruction updates, editing	10/22/24